



## Electrochemical Cells – Supplementary Worksheet

### Experimental Observations of Electrochemical Cells

1. Consider the voltaic cell that contains standard  $\text{Co}^{2+}/\text{Co}$  and  $\text{Au}^{3+}/\text{Au}$  electrodes. The following experimental observations were noted: (1) Metallic gold plates out on one electrode and the gold ion concentration decreases around that electrode, and (2) The mass of the cobalt electrode decreases and the cobalt (II) ion concentration increases around that electrode.
  - a. Diagram this voltaic cell. Make sure to
    - i. Indicate the anode, cathode, positive and negative electrodes
    - ii. Write out the  $\frac{1}{2}$  reactions and their type occurring at each electrode
    - iii. Write out the overall balanced redox reaction that goes with this cell
    - iv. Label the direction of electron flow and the current
    - v. Label the direction of anions and cations in the salt bridge
  - b. Diagram the cell using the short hand notation
  - c. What is the standard cell potential of this voltaic cell?
2. Consider the electrolysis of molten calcium chloride with inert electrodes. The following experimental observations were noted: (1) Bubbles of pale green chlorine gas are produced at one electrode, and (2) Silvery white molten metallic calcium is produced at the other electrode.
  - a. Diagram this electrolytic cell. Make sure to
    - i. Indicate the anode, cathode, positive and negative electrodes
    - ii. Write out the  $\frac{1}{2}$  reactions and their type occurring at each electrode
    - iii. Write out the overall balanced redox reaction that goes with this cell
    - iv. Label the direction of electron flow and the current
    - v. Label the direction of anions and cations in the salt bridge
  - b. Diagram the cell using the short hand notation
  - c. What is the standard cell potential of this electrolytic cell?
3. Problem 1 is an example of a galvanic or voltaic cell. Problem 2 is an example of an electrolytic cell. Considering the diagrams of these two cells, what are the differences and similarities between galvanic (voltaic) cells and electrolytic cells?

### Short Hand Notation of Electrochemical Cells

4. Consider the following cell  $\langle \text{Ni(s)}|\text{Ni}^{2+}(\text{aq})||\text{Ag}^{+}(\text{aq})|\text{Ag(s)}\rangle$ 
  - a. Diagram this cell. Make sure to
    - i. Indicate the anode, cathode, positive and negative electrodes
    - ii. Write out the  $\frac{1}{2}$  reactions and their type occurring at each electrode
    - iii. Write out the overall balanced redox reaction that goes with this cell
    - iv. Label the direction of electron flow and the current
    - v. Label the direction of anions and cations in the salt bridge
  - b. What is the standard cell potential of this cell?
  - c. Is this cell a galvanic cell or an electrolytic cell?
5. Consider the following cell

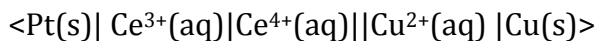

- Diagram this cell. Make sure to
  - Indicate the anode, cathode, positive and negative electrodes
  - Write out the  $\frac{1}{2}$  reactions and their type occurring at each electrode
  - Write out the overall balanced redox reaction that goes with this cell
  - Label the direction of electron flow and the current
  - Label the direction of anions and cations in the salt bridge
- What is the standard cell potential of this cell?
- Is this cell a galvanic cell or an electrolytic cell?

### Electrochemical Cell Diagrams

- Consider the following cell:

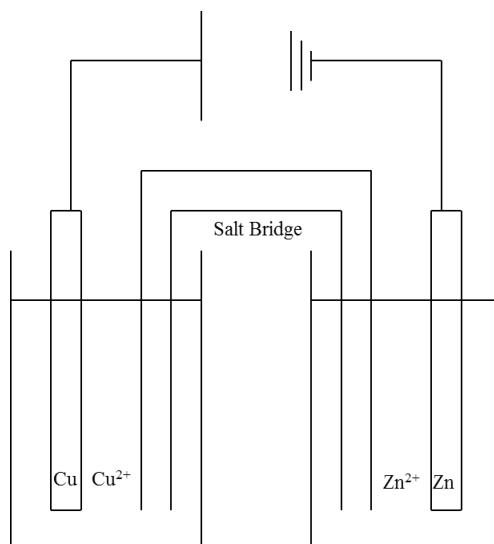

- Would you assume this cell is a voltaic or an electrolytic cell? Why do you think this?
- Knowing this complete the diagram of this cell by
  - Indicating the anode, cathode, positive and negative electrodes
  - Writing out the  $\frac{1}{2}$  reactions and their type occurring at each electrode
  - Writing out the overall balanced redox reaction that goes with this cell
  - Labeling the direction of electron flow and the current
  - Labeling the direction of anions and cations in the salt bridge
- What is the short hand notation for this cell?
- What is the standard cell potential of this cell?

7. Consider the following cell:

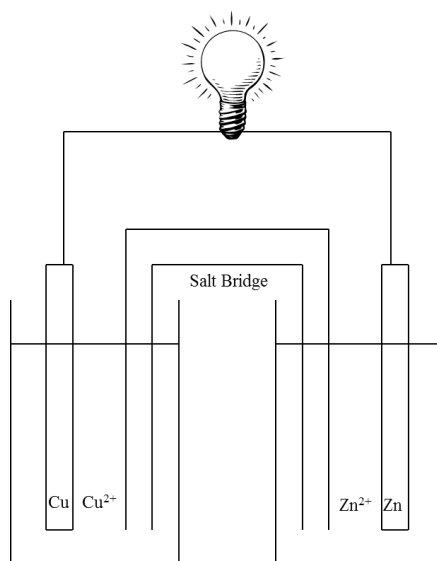

- Would you assume this cell is a voltaic or an electrolytic cell? Why do you think this?
  - Knowing this complete the diagram of this cell by
    - Indicating the anode, cathode, positive and negative electrodes
    - Writing out the  $\frac{1}{2}$  reactions and their type occurring at each electrode
    - Writing out the overall balanced redox reaction that goes with this cell
    - Labeling the direction of electron flow and the current
    - Labeling the direction of anions and cations in the salt bridge
  - What is the short hand notation for this cell?
  - What is the standard cell potential of this cell?
8. The cells in problems 6 and 7 have almost the same components. However, one is galvanic and one is electrolytic. What are some of the similarities and differences between these two problems?